

DEVELOPMENT DATA

This data sheet contains advance information and specifications are subject to change without notice.

TDA5709

RADIAL ERROR SIGNAL PROCESSOR FOR COMPACT DISC PLAYERS

GENERAL DESCRIPTION

The TDA5709 is a bipolar integrated circuit which provides control signals for the radial motor. These control signals are generated from radial error signals received from a photo-diode signal processor (TDA5708), and velocity control signals from the control processor.

Features

- Tracking error processor with automatic asymmetry control
- A.G.C. circuitry with automatic start-up and wobble generator
- Tracking control for fast forward/reverse scan, search, repeat and pause functions
- TTL compatible digital input/output
- Digitalized tracking error signal
- Possibility for car application

QUICK REFERENCE DATA

Supply voltage range	$V_{DD}-V_{BB}$	8 to 13 V
Quiescent supply current	I_Q	typ. 6 mA
Operating ambient temperature range	T_{amb}	-30 to +85 °C

PACKAGE OUTLINE

20-lead DIL; plastic (SOT146).

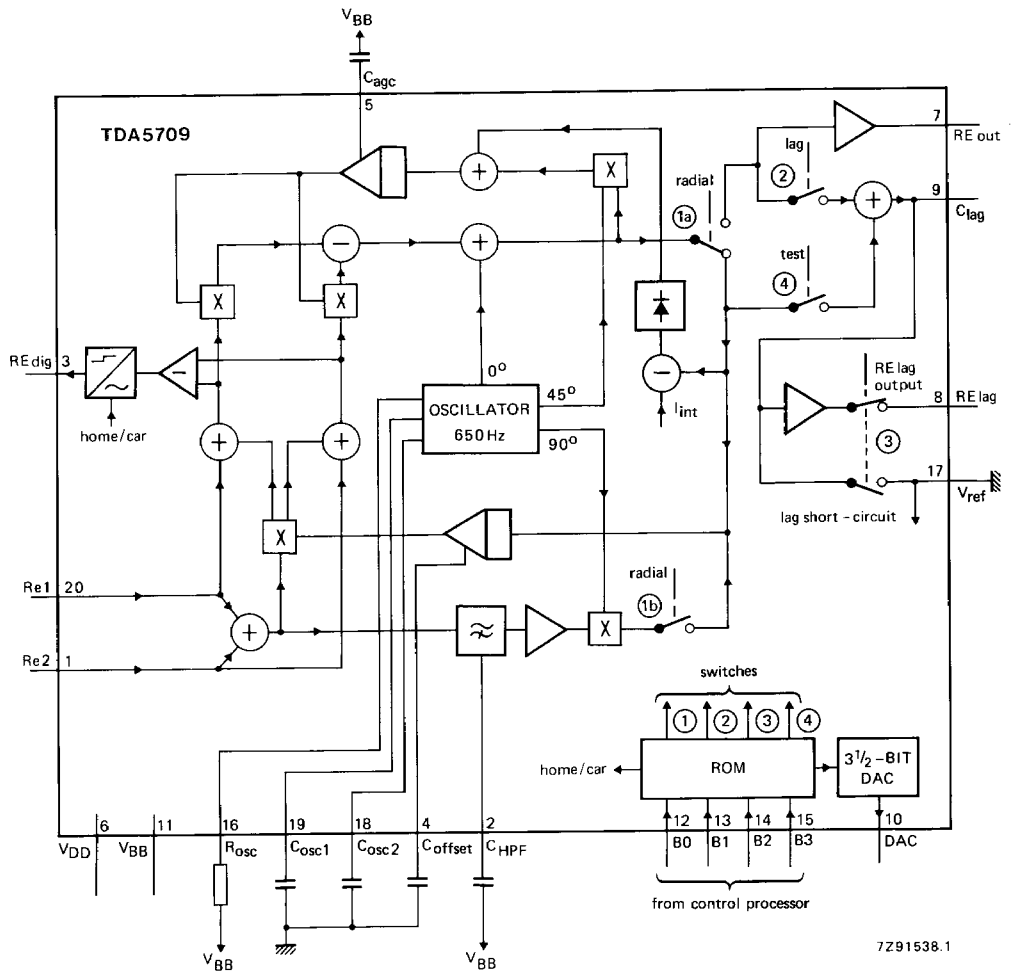

Fig. 1 Block diagram.

PIN DESCRIPTION

Pin No.	Symbol	Description
1	Re2	Input for amplified currents from photo diodes D1 and D2
2	C _{HPPF}	High-pass filter for Re1 and Re2, used for radial offset control
3	REdig	Digital output of sign (Re2 – Re1)
4	C _{offset}	Offset control input for radial offset
5	C _{agc}	Gain control input for radial error signal
6	V _{DD}	Positive supply voltage
7	REout	Current output of amplified (Re2 – Re1) input currents
8	RElag	Voltage output of integrated (Re2 – Re1) input currents
9	C _{lag}	Integrator capacitor for (Re1 – Re2) input currents
10	DAC	Current output for track jumping (3½ bits)
11	V _{BB}	Negative supply connection (also substrate connection)
12	B0	Input control bits for off-, catch-, play-status and DAC output current
13	B1	
14	B2	
15	B3	
16	R _{osc}	Biassing resistor for oscillator frequency and internal amplitude
17	V _{ref}	Intermediate supply voltage
18	C _{osc2}	Frequency setting capacitors for oscillator
19	C _{osc1}	
20	Re1	Input for amplified currents from photo-diodes D3 and D4

DEVELOPMENT DATA

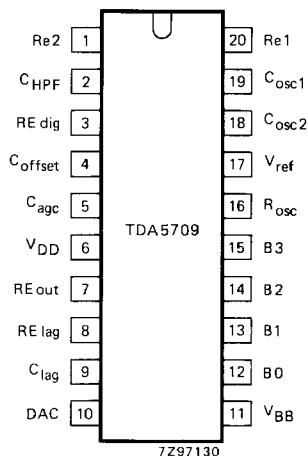

Fig. 2 Pinning diagram.

RATINGS

Limiting values in accordance with the Absolute Maximum System (IEC 134)

Supply voltage range ($V_{DD} - V_{BB}$)
pin 6 – pin 11

$V_{DD} - V_{BB}$ -0,3 to +13 V

Total power dissipation

P_{tot} see Fig. 3

Storage temperature range

T_{stg} -55 to +150 °C

Operating ambient temperature range

T_{amb} -30 to +85 °C

Operating junction temperature

T_j max. 150 °C

THERMAL RESISTANCE

From junction to ambient

$R_{th\ j-a}$ = 72 K/W

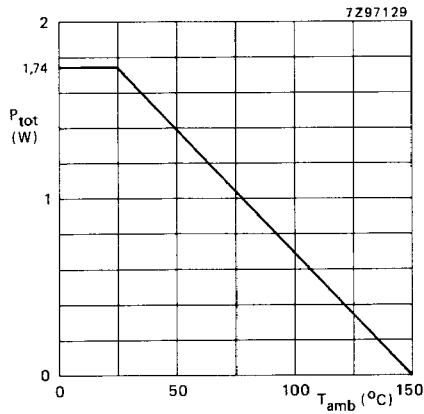

Fig. 3 Power derating curve.

CHARACTERISTICS

$V_{DD} = +5\text{ V}$; $V_{BB} = -5\text{ V}$; $T_{amb} = 25\text{ }^{\circ}\text{C}$; $V_{ref} = 0\text{ V}$; $R_{osc} = 24\text{ k}\Omega$; all voltages with respect to V_{ref} ; unless otherwise specified.

DEVELOPMENT DATA

parameter	symbol	min.	typ.	max.	unit
Supplies					
Supply voltage					
pin 6 – pin 11 ($V_{DD} - V_{BB}$)		8	–	13	V
pin 17 – pin 11 ($V_{ref} - V_{BB}$)		4,5	5,0	5,5	V
Quiescent supply current	I_Q	–	6	–	mA
REdig output (pin 3)					
Output voltage level					
HIGH (note 1; C)	V_{REdig}	$V_{ref} + 2,4$	–	–	V
LOW (note 1; A)	V_{REdig}	$V_{ref} - 0,3$	–	$V_{ref} + 0,4$	V
LOW (note 1; B)	V_{REdig}	V_{BB}	–	$V_{BB} + 0,4$	V
Output current					
sink current (note 1; A or B)	I_{REdig}	400	–	–	μA
source current (note 1; C)	I_{REdig}	–	–150	–50	μA
Digital inputs (pins 12 to 15)					
B0, B1, B2 and B3					
Input voltage HIGH (note 2)	V_B	$V_{ref} + 2$	–	V_{DD}	V
Input voltage LOW (note 2)	V_B	$V_{BB} + 2$	–	$V_{ref} + 0,8$	V
Input voltage HIGH (note 3)	V_B	$V_{BB} + 2$	–	V_{DD}	V
Input voltage LOW (note 3)	V_B	$V_{BB} - 0,3$	–	$V_{BB} + 0,8$	V
Input current					
at $V_B = \text{HIGH}$	I_B	–	0	–	μA
at $V_B = \text{LOW}$	I_B	–	–	–10	μA
DAC output (pin 10)					
Output voltage range					
at $I_{DAC} = +150\text{ }\mu\text{A}$ (sink current)	V_{DAC}	$V_{BB} + 1,5$	–	V_{DD}	V
at $I_{DAC} = -150\text{ }\mu\text{A}$ (source current)	V_{DAC}	V_{BB}	–	$V_{DD} - 1$	V
Output impedance					
at $I_{DAC} = 200\text{ }\mu\text{A}$	$ Z_{DAC} $	–	50	–	$\text{M}\Omega$

CHARACTERISTICS (continued)

parameter	symbol	min.	typ.	max.	unit
DAC output (continued)					
Ratio of output current pin 10 to pin 16 (see Table 1)	I_{10}/I_{16}	3,6 -4,6 0,9 -1,2 0,68 -0,86 0,45 -0,58 0,23 -0,29	4 -4 1 -1 0,75 -0,75 0,5 -0,5 0,25 -0,25	4,4 -3,4 1,1 -0,8 0,82 -0,64 0,55 -0,42 0,27 -0,2	
Analogue input (pin 16)					
Input voltage level	V_{Rosc}	-	$V_{BB} + 1,2$	-	V
Input current level	I_{Rosc}	-	-50	-	μA
Radial error inputs (Re1 pin 20, Re2 pin 1)					
Input voltage level at $I_{Re1}, I_{Re2} = -105 \mu A$	V_{Re1}, V_{Re2}	-	$V_{BB} + 1,4$	-	V
Input current	I_{Re1}, I_{Re2}	-	105	-	μA
Input impedance	$ Z_{Re1} , Z_{Re2} $	-	1	-	k Ω
Gain control input (pin 5)					
Input voltage for minimum radial gain	V_{Cagc}	-	$V_{BB} + 3,5$	-	V
maximum radial gain	V_{Cagc}	-	$V_{BB} + 5,5$	-	V
Input impedance	$ Z_{Cagc} $	-	20	-	M Ω
Offset control (pin 4)					
Output current at $I_{Re1} = I_{Re2} = -105 \mu A$; $V_{Cosc1} = V_{Cosc2} = V_{ref}$	$-I_{Coffset}$	-	0,25	-	μA
Input voltage for maximum amplification Re1	$V_{Coffset}$	-	$V_{ref} - 1$	-	V
minimum amplification Re2	$V_{Coffset}$	-	$V_{ref} - 1$	-	V
minimum amplification Re1	$V_{Coffset}$	-	$V_{ref} + 1$	-	V
maximum amplification Re2	$V_{Coffset}$	-	$V_{ref} + 1$	-	V
Input impedance	$ Z_{Coffset} $	-	30	-	M Ω

DEVELOPMENT DATA

parameter	symbol	min.	typ.	max.	unit
High-pass filter (pin 2)					
Voltage level at $I_{Re1} = I_{Re2} = 0$	V_{HPF}	—	$V_{BB} + 2,8$	—	V
Impedance	$ Z_{HPF} $	—	5	—	$k\Omega$
Oscillator (C_{Osc1} pin 19, C_{Osc2} pin 18)					
Linear input voltage range V_{Coscl} , V_{Coscl2}	V_{Coscl}	$V_{ref} - 2$	—	$V_{ref} + 2$	V
RElag voltage output (pin 8)					
Output voltage range at $I_{RElag} = +200 \mu A$ (sink current)	V_{RElag}	$V_{BB} + 1,5$	—	V_{DD}	V
at $I_{RElag} = -200 \mu A$ (source current)	V_{RElag}	V_{BB}	—	$V_{DD} - 1$	V
Maximum source current output	I_{RElag}	—	-2,5	—	mA
Maximum sink current output	I_{RElag}	—	4	—	mA
Output impedance ($f < 10$ kHz) with RElag switched on	$ Z_{RElag} $	—	—	50	Ω
with RElag switched off	$ Z_{RElag} $	1	—	—	$M\Omega$
REout push-pull current output (pin 7)					
Output voltage range at $I_{REout} = +40 \mu A$ (sink current)	V_{REout}	$V_{BB} + 1,5$	—	V_{DD}	V
at $I_{REout} = -40 \mu A$ (source current)	V_{REout}	V_{BB}	—	$V_{DD} - 1$	V
Output impedance	$ Z_{REout} $	—	2	—	$M\Omega$
Clag push-pull current output/voltage input (pin 9)					
Output voltage range at $I_{Clag} = +4 \mu A$ (sink current)	V_{Clag}	$V_{BB} + 1,5$	—	V_{DD}	V
at $I_{Clag} = -4 \mu A$ (source current)	V_{Clag}	V_{BB}	—	$V_{DD} - 1,5$	V
Output impedance	$ Z_{Clag} $	—	15	—	$M\Omega$

CHARACTERISTICS (continued)

parameter	symbol	min.	typ.	max.	unit
TRANSFER SPECIFICATIONS					
Oscillator (pins 19, 18)					
(V _{osc1} , V _{osc2} : -2 V to +2 V)					
Transconductance factor					
$\frac{I_{Cosc2}}{V_{Cosc1}} \cdot R_{osc}$		-	0,48	-	
$\frac{I_{Cosc1}}{V_{Cosc2}} \cdot R_{osc}$		-	-0,48	-	
Amplitude stabilization					
I _{osc1} = f(V _{osc1}) at V _{Cosc2} = 0					
V _{osc1} = 0 V	I _{osc1}	-	0,1	-	μA
V _{osc1} = +0,87 V	I _{osc1}	-	M ₂ + 1,4	-	μA
V _{osc1} = -0,87 V	I _{osc1}	-	M ₂ - 1,4	-	μA
V _{osc1} = +1,2 V	I _{osc1}	-	M ₂	-	μA
V _{osc1} = -1,2 V	I _{osc1}	-	M ₂	-	μA
V _{osc1} = +1,8 V	I _{osc1}	-	M ₂ - 3,5	-	μA
V _{osc1} = -1,8 V	I _{osc1}	-	M ₂ + 3,5	-	μA
(note 4)					
Amplitude stabilization					
I _{osc2} = f(V _{osc2}) at V _{Cosc1} = 0					
V _{osc2} = 0 V	I _{osc2}	-	0,1	-	μA
V _{osc2} = +0,87 V	I _{osc2}	-	M ₃ + 1,4	-	μA
V _{osc2} = -0,87 V	I _{osc2}	-	M ₃ - 1,4	-	μA
V _{osc2} = +1,2 V	I _{osc2}	-	M ₃	-	μA
V _{osc2} = -1,2 V	I _{osc2}	-	M ₃	-	μA
V _{osc2} = +1,8 V	I _{osc2}	-	M ₃ - 3,5	-	μA
V _{osc2} = -1,8 V	I _{osc2}	-	M ₃ + 3,5	-	μA
(note 5)					
Transconductance factor					
$\frac{I_{Clag}}{V_{osc1}} \cdot R_{osc}$					
with test on; radial off;					
I _{Re1} = I _{Re2} = 0		-	-0,08	-	

DEVELOPMENT DATA

parameter	symbol	min.	typ.	max.	unit
Transconductance factor					
$\frac{I_{Clag}}{V_{osc1}} \cdot R_{osc}$ with lag on; radial on; $I_{Re1} = I_{Re2} = 0$		—	—0,08	—	
Transconductance factor					
$\frac{I_{REout}}{V_{osc2}} \cdot R_{osc}$ with radial on; $I_{Re1} = I_{Re2} = 0$		—	0	—	
$\frac{I_{REout}}{V_{osc1}} \cdot R_{osc}$ with radial on; $I_{Re1} = I_{Re2} = 0$		—	0,8	—	
Transconductance factor					
$\frac{I_{Coffset}}{V_{Cosc2}} \cdot R_{osc}$ with radial on; $I_{Re1} = I_{Re2} = 0$ at $I_{HPF} = 30 \mu A$		—	0,48	—	
at $I_{HPF} = 0 \mu A$		—	0	—	
at $I_{HPF} = -30 \mu A$		—	-0,48	—	
with radial off; $I_{Re1} = I_{Re2} = 0$ at $I_{HPF} = 30 \mu A$		—	0	—	
Transconductance factor					
$\frac{I_{Coffset}}{V_{Cosc1}} \cdot R_{osc}$ with radial on; $I_{Re1} = I_{Re2} = 0$ at $I_{HPF} = 30 \mu A$		—	0	—	
with radial off; $I_{Re1} = I_{Re2} = 0$ at $I_{HPF} = 30 \mu A$		—	0,08	—	
Transconductance factor					
$\frac{I_{agc}}{V_{Cosc1}} \cdot R_{osc}$ with radial on; $V_{agc} = 0,5 V$; $V_{Coffset} = V_{Cosc2} = 0 V$ at $I_{Re1} = -150 \mu A$; $I_{Re2} = 0$		—	-0,48	—	
at $I_{Re1} = I_{Re2} = -100 \mu A$		—	note 6	—	
at $I_{Re1} = 0$; $I_{Re2} = -150 \mu A$		—	+0,48	—	

CHARACTERISTICS (continued)

parameter	symbol	min.	typ.	max.	unit
Transconductance factor					
$\frac{I_{agc}}{V_{Cosc2}} \cdot R_{osc}$ with radial on; $V_{agc} = 0,5 \text{ V}$; $V_{offset} = V_{Cosc1} = 0 \text{ V}$ at $I_{Re1} = -150 \mu\text{A}$; $I_{Re2} = 0$ at $I_{Re1} = I_{Re2} = -100 \mu\text{A}$ at $I_{Re1} = 0$; $I_{Re2} = -150 \mu\text{A}$		—	—0,48 0 +0,48	—	
Transfer $C_{lag} \rightarrow RE_{lag}$					
$\frac{V_{RE_{lag}}}{V_{Clag}}$; at frequencies < 10 kHz with lag short-circuit off; RE _{lag} output on		—	1	—	
Slew rate					
RE _{lag} amplifier with lag short-circuit off; RE _{lag} output on	SR	—	0,4	—	V/ μs
Switch lag short-circuit					
Impedance $\frac{\Delta V_{Clag}}{\Delta I_{Clag}}$ with lag short-circuit on; $ I_{Clag} < 10 \mu\text{A}$	$ Z_{lag\ sc} $	—	—	1	k Ω
Offset $ V_{Clag} - V_{ref} $ with lag short-circuit on; $I_{Clag} = 0 \mu\text{A}$	$ V_{RE_{lag}} $	—	—	10	mV
Transfer resistance (Re1, Re2 to C_{HPF})					
$\frac{\Delta V_{CHPF}}{\Delta(I_{Re1} + I_{Re2})}$		—	2,5	—	k Ω
Gain (Re1, Re2 to RE_{out})					
$\frac{\Delta I_{REout}}{\Delta(I_{Re1} - I_{Re2})}$ with lag short-circuit on; radial on; $V_{Coffset} = V_{osc1} = V_{osc2} = 0 \text{ V}$ $V_{agc} = 0,5 \text{ V}$		—	5	—	times

DEVELOPMENT DATA

parameter	symbol	min.	typ.	max.	unit
Offset current RE Offset current with lag short-circuit on; radial on; $V_{Coffset} = V_{osc1} = V_{osc2} = 0\text{ V}$ $V_{agc} = 0,5\text{ V}$ at $I_{Re1} = I_{Re2} = 100\text{ }\mu\text{A}$	I_{RE}	—	0	—	μA
Gain (Re1, Re2 to C_{agc}) $\frac{\Delta I_{Cagc}}{\Delta(I_{Re1} - I_{Re2})}$ at $I_{Re1} = -104\text{ }\mu\text{A}$ with lag short-circuit on; radial on; $V_{Coffset} =$ (see note 7); $V_{agc} = 0,5\text{ V}$; $V_{Cosc1} = 0\text{ V}$; $V_{Cosc2} = 1,2\text{ V}$; $\Delta(I_{Re1} - I_{Re2}) = 8\text{ }\mu\text{A}$		—	0,8	—	times
$\frac{\Delta I_{Cagc}}{\Delta(I_{Re1} - I_{Re2})}$ at $I_{Re2} = -104\text{ }\mu\text{A}$ with lag short-circuit on; radial on; $V_{Coffset} =$ (note 7); $V_{agc} = 0,5\text{ V}$; $V_{Cosc1} = 0\text{ V}$; $V_{Cosc2} = 1,2\text{ V}$; $\Delta(I_{Re2} - I_{Re1}) = 8\text{ }\mu\text{A}$		—	-0,8	—	times
Offset current I_{Cagc} Offset current with lag short-circuit on; radial on; $V_{Cosc1} = 0\text{ V}$; $V_{Cosc2} = 0\text{ V}$ $V_{agc} = 0,5\text{ V}$ at $I_{Re1} = I_{Re2} = -100\text{ }\mu\text{A}$	I_{Cagc}	—	0	—	μA
Transconductance factor $\frac{\Delta I_{RE} \cdot V_{RANGE}}{I_{tot} \cdot V_{Coffset}}$ with $V_{Cosc1} = V_{Cosc2} = 0\text{ V}$; radial on; $V_{agc} = -3\text{ V}$; $V_{RANGE} = 1\text{ V}$ (internal); $I_{tot} = I_{Re1} + I_{Re2}$ at $I_{Re1} = I_{Re2} = -100\text{ }\mu\text{A}$		—	2,5	—	
$\frac{\Delta I_{RE} \cdot V_{RANGE}}{I_{tot} \cdot V_{Coffset}}$ with $V_{Cosc1} = V_{Cosc2} = 0\text{ V}$; radial on; $V_{agc} = V_{BB}$; $V_{RANGE} = 1\text{ V}$ (internal); $I_{tot} = I_{Re1} + I_{Re2}$ at $I_{Re1} = I_{Re2} = -100\text{ }\mu\text{A}$		—	0	—	

CHARACTERISTICS (continued)

parameter	symbol	min.	typ.	max.	unit
Gain control current I_{agc}					
I_{agc} with $V_{Cosc1} = V_{Cosc2} = 0\text{ V}$; $V_{agc} = 0,5\text{ V}$; radial off; $V_{Coffset} = 0\text{ V}$					
at $I_{REtot} = 200\text{ }\mu\text{A}$; $I_{Re1} - I_{Re2} = 35\text{ }\mu\text{A}$	I_{agc}	—	0	—	μA
at $I_{REtot} = 200\text{ }\mu\text{A}$; $I_{Re1} - I_{Re2} = 65\text{ }\mu\text{A}$	I_{agc}	—	50	—	μA

Notes to the characteristics

1. REdig output conditions:

A: $I_{Re1} > I_{Re2} + 5\text{ }\mu\text{A}$; $V_{Coffset} = V_{ref}$; B0 and B1 and B2 and B3 $> V_{BB} + 2,0\text{ V}$.

B: $I_{Re1} > I_{Re2} + 5\text{ }\mu\text{A}$; $V_{Coffset} = V_{ref}$; B0 or B1 or B2 or B3 $< V_{BB} + 0,8\text{ V}$.

C: $I_{Re2} > I_{Re1} + 5\text{ }\mu\text{A}$; $V_{Coffset} = V_{ref}$; don't cares for B0, B1, B2 and B3.

2. In the 'home' application all logical inputs B0, B1, B2 and B3 must be $> V_{BB} + 2\text{ V}$.

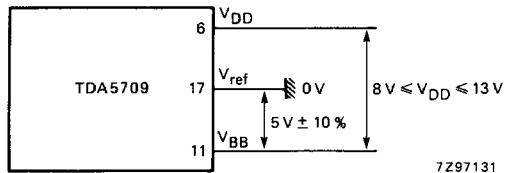

Fig. 4 TDA5709 'home' application.

3. In the 'car' application one or more of the logical inputs B0, B1, B2, B3 must be $< V_{BB} + 0,8\text{ V}$.

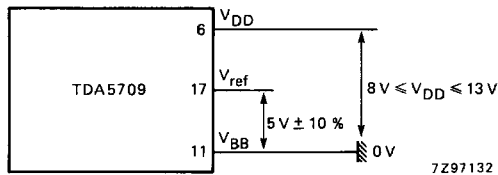

Fig. 5 TDA5709 'car' application.

4. M_2 is the measured value of I_{osc1} at $V_{osc1} = 0\text{ V}$.

5. M_3 is the measured value of I_{osc2} at $V_{osc2} = 0\text{ V}$.

6. Parabolic curve.

7. $V_{Coffset}$ must be adjusted so that $I_{Clag} = 4\text{ }\mu\text{A}$.

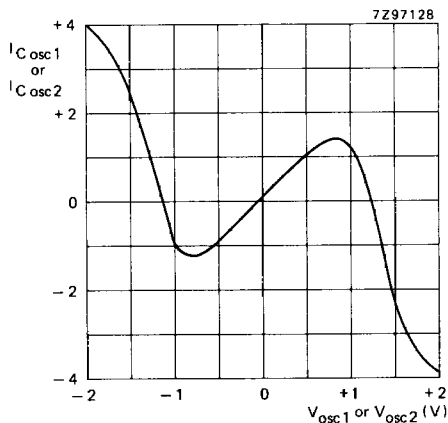

Fig. 6 Amplitude stabilization (typical curve).

Table 1 Truth table for DAC output current

DEVELOPMENT DATA

type names	DAC output (μA)*	logical inputs				internal switches				
		B0	B1	B2	B3	lag	lag s/c	rad	test	output RElag
OFF	0	0	0	0	0	off	on	off	off	off
CATCH	0	0	0	0	1	off	on	on	off	off
PUSH	-200	0	0	1	0	off	on	off	off	off
(kick)	-200	0	0	1	1	off	off	off	off	on
PULL	50	0	1	0	0	off	on	off	off	off
PULL	37,5	0	1	0	1	off	on	off	off	off
PULL	25	0	1	1	0	off	on	off	off	off
PULL	12,5	0	1	1	1	off	on	off	off	off
PUSH	-50	1	0	0	0	off	on	off	off	off
PUSH	-37,5	1	0	0	1	off	on	off	off	off
PUSH	-25	1	0	1	0	off	on	off	off	off
PUSH	-12,5	1	0	1	1	off	on	off	off	off
PULL	200	1	1	0	0	off	on	off	off	off
(kick)	200	1	1	0	1	off	off	off	off	on
play	0	1	1	1	0	on	off	on	off	on
test**	0	1	1	1	1	off	off	off	on	on

Where:

0 = input voltage LOW; 1 = input voltage HIGH.

* With $R_{Osc} = 24 \text{ k}\Omega$.

** Non-proper operating of output REdig if the logical zero is close to V_{BB} .