

SM5861AP (D/A converter)

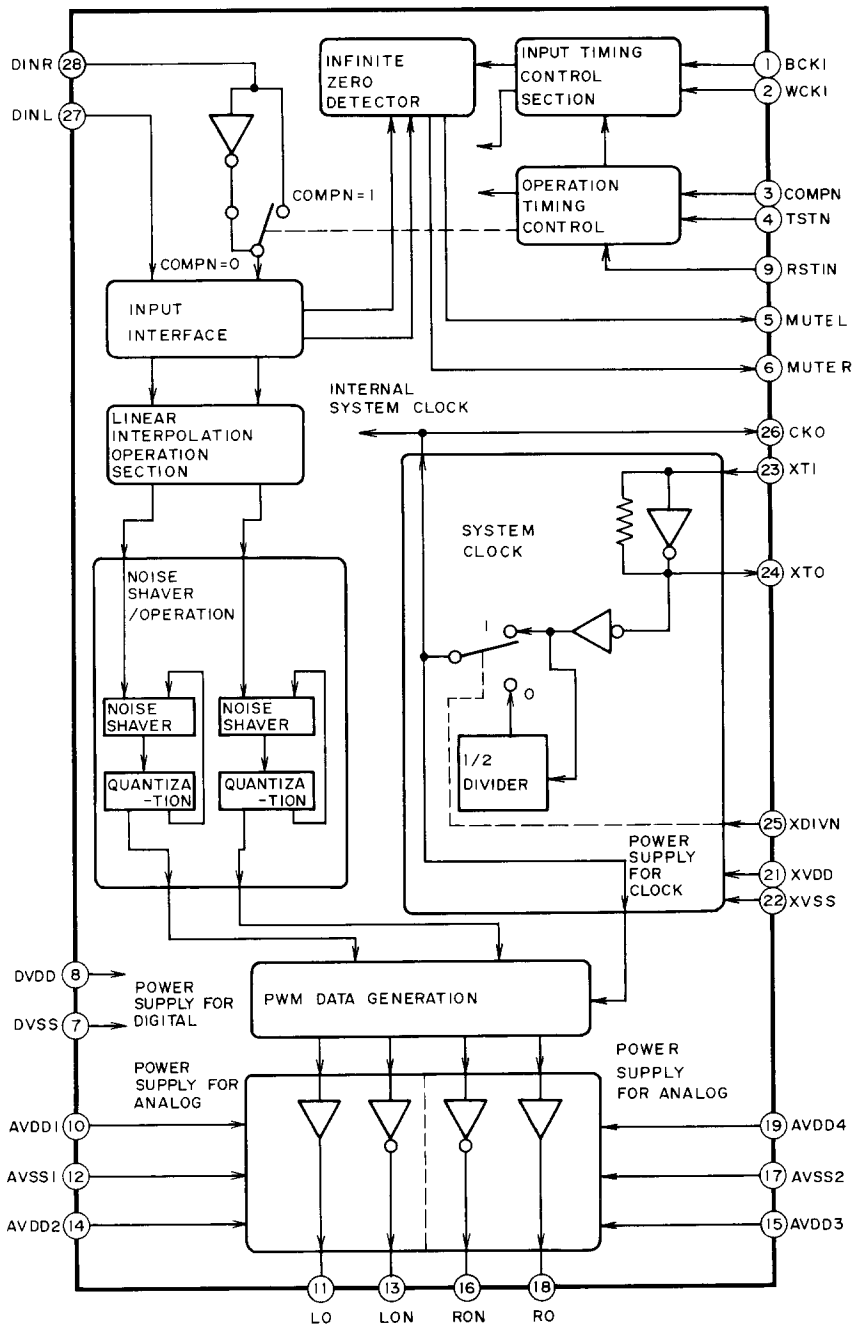

Pin No.	Symbol	Description	Pin No.	Symbol	Description
1	BCKI	Serial input data bit clock	15	AVDD3	5V supply for analogue section
2	WCKI	Input data word clock	16	RON	Data output right channel
3	COMPN	Mode select of PWM output	17	AVSS2	Ground for analogue section
4	TSTN	Test terminal	18	RO	Data output right channel
5	MUTEL	Muting output for left channel	19	AVDD4	Ground for analogue section
6	MUTER	Muting output for right channel	20	NC	
7	DVSS	Ground for digital section	21	XVDD	5V supply for clock section
8	DVDD	5V power supply for digital section	22	XVSS	Ground for clock section
9	RSTIN	Reset input	23	XTI	Crystal oscillator input
10	AVDD1	5V supply for analogue section	24	XTO	Crystal oscillator output
11	LO	Data output left channel	25	XDIVN	System clock select
12	AVSS1	Ground for analogue section	26	CKO	Clock output
13	LON	Data output left channel	27	DINL	Serial data input for left channel
14	AVDD2	5V supply for analogue section	28	DINR	Serial data input for right channel