

GENERAL DESCRIPTION

The SAA7010 demodulates and decodes the pulse code modulated input signal into digital data for the Compact Disc Digital Audio system. A 4,3 MHz (typical) clock locked to the disc rate is also produced.

Features

- Phase-locked loop clock regenerator with frequency detector for locking
- High-frequency level detector with adaptive slicer for input data
- Built-in drop-out detector to prevent error propagation in adaptive slicer
- Outputs to subcoding microprocessor
- Fully protected timing synchronization to incoming data

3

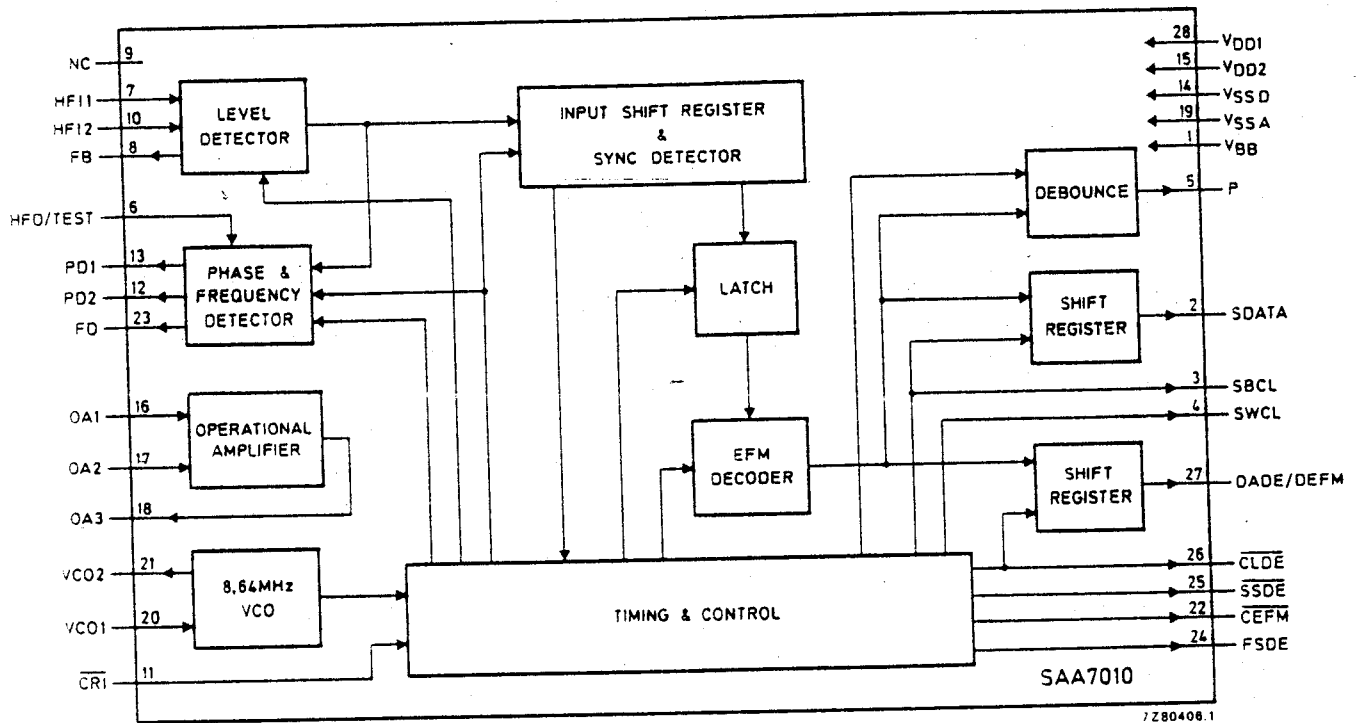

Fig. 1 Block diagram.

PACKAGE OUTLINE

28-lead DIL; package (SOT-117).

DEMODULATOR FOR COMPACT DISC

SAA7010

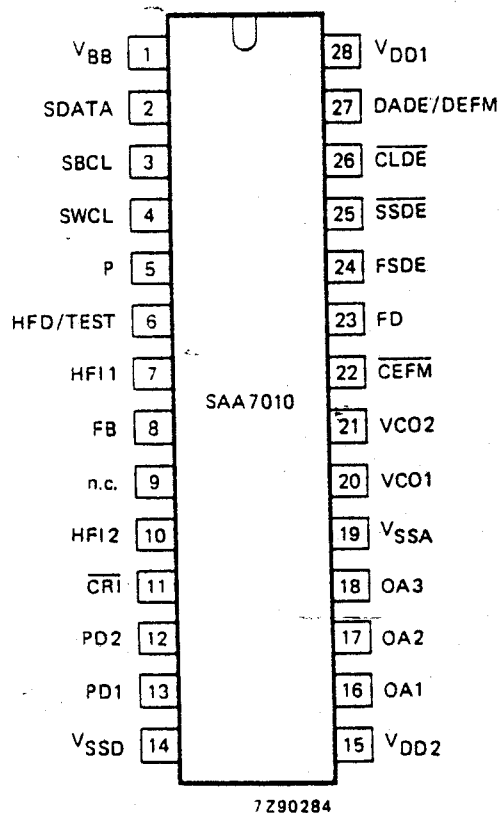

Fig. 2 Pinning diagram.

PINNING

1	V _{BB}	back bias supply
2	SDATA	subcoding data output
3	SBCL	subcoding bit clock output
4	SWCL	subcoding word clock output
5	P	subcoding pause bit output
6	HFD/TEST	high-frequency detector input in normal operation. Selects test mode when at V _{DD2}
7	HFI1	level detector input
8	FB	current feedback from level detector
9	n.c.	not connected
10	HFI2	alternative input to level detector
11	CRI	counter reset inhibit input
12	PD2	phase detector reference output
13	PD1	phase detector signal output
14	V _{SSD}	digital ground
15	V _{DD2}	+ 12 V supply
16	OA1	operational amplifier non-inverting input
17	OA2	operational amplifier inverting input
18	OA3	operational amplifier source-follower output
19	V _{SSA}	analogue ground
20	VCO1	voltage-controlled oscillator amplifier input
21	VCO2	voltage-controlled oscillator amplifier output
22	CEFM	4,3218 MHz clock output
23	FD	frequency detector output
24	FSDE	frame sync signal output
25	SSDE	symbol sync signal output
26	CLDE	data bit clock output
27	DADE/DEFM	serial data output/EFM digital output: selection determined by level at pin 11
28	V _{DD1}	+ 5 V supply

FUNCTIONAL DESCRIPTION

The SAA7010 demodulator forms the front-end of the Compact Disc Digital Audio system, supplying demodulated data and timing signals to the error corrector (SAA7020) and to the subcoding micro-processor.

The detected signal from the disc is amplified and filtered externally and then converted to a digital signal via the level detector. The level detector is an adaptive data slicer which relies on the nature of the modulation system to determine the optimum slicing level.

A frequency detector and a phase detector provide the coarse and fine control signals for the phase-locked loop (PLL) system. The loop gain is supplied by an internal operational amplifier which drives a voltage-controlled oscillator (VCO) running at twice the input data rate (typically 8,6436 MHz). The VCO output is divided by two by a clock generator in the timing and control circuits and the resulting output is used to clock the input shift register and the timing chain. This clock signal completes the PLL loop when it is compared with the incoming data in the phase detector.

After phase detection the data is clocked into the 23-bit input shift register which then detects the frame sync pattern. Within the timing and control circuits are minimum and maximum data length detectors which provide frequency limit signals for the frequency detector.

Also within the timing and control circuits are two divide-by-588 counters, one master and one slave, two divide-by-17 symbol rate counters and a lock indication counter. The frame sync signal is used to reset the divide-by-588 slave counter. This counter and one divide-by-17 symbol rate counter supply timing signals for clocking the EFM (eight-to-fourteen modulation) decoder and the subcoding output timing circuits. The data is read from the input shift register in 14-bit symbols which are first latched and then decoded into 8-bit data words. The subcoding part of the data consists of one word per frame (Fig. 3), so the output SDATA comprises a burst of 8 data bits accompanied by a 2,1906 MHz clock burst signal SBCL (Fig. 4). One bit of this subcoding output data is replaced by a subcoding frame sync bit which is decoded from one of two special EFM codes. The displaced bit (the pause (P) bit) is latched to its own output via a debounce circuit to remove erroneous changes.

The divide-by-588 slave counter also provides a sync coincidence pulse which occurs when two detected sync pulses are precisely one frame apart (588 clock cycles). The sync coincidence pulse is used to reset the lock indication counter and disable the FD output from the frequency detector. If the system goes out of lock, the sync pulses cease and the lock indication counter counts frame periods. After 63 frame periods with no sync coincidence pulse, the lock indication counter enables the frequency detector output.

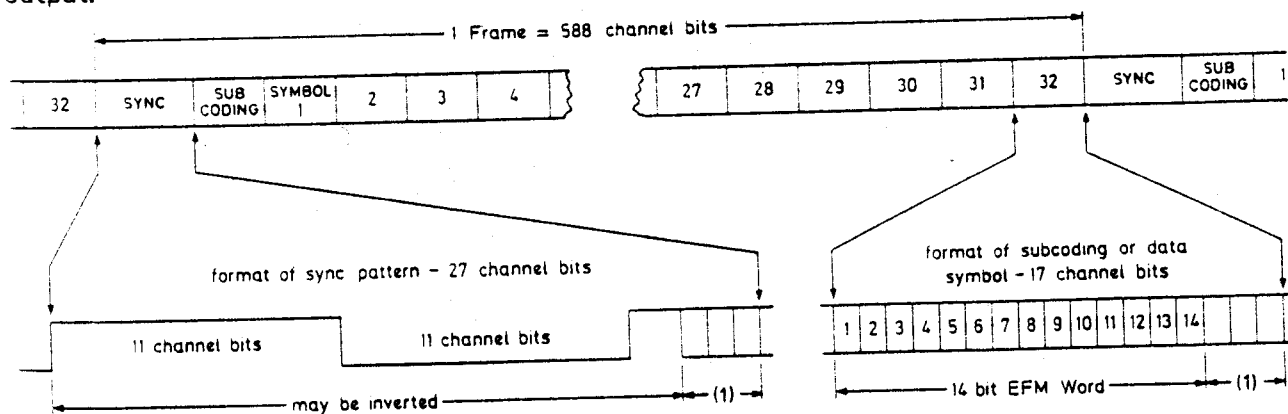

7280408

(1) Merging and low frequency suppression bits.

Fig. 3 Data input signal.

Signetics

FUNCTIONAL DESCRIPTION (continued)

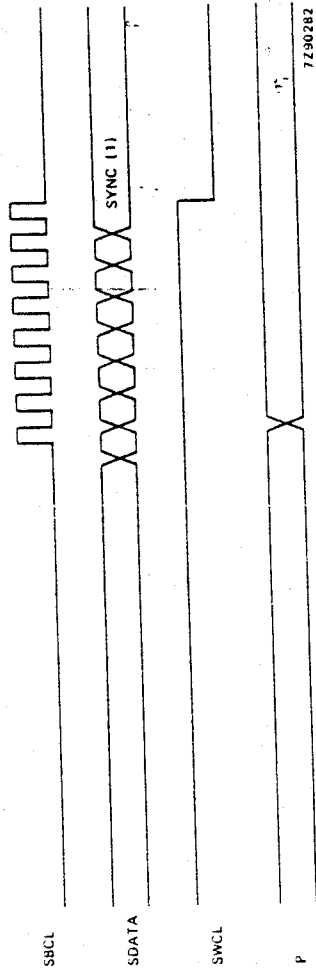

(1) The sync bit is LOW when a subcoding sync word is detected.

Fig. 4 Typical subcoding waveform outputs.

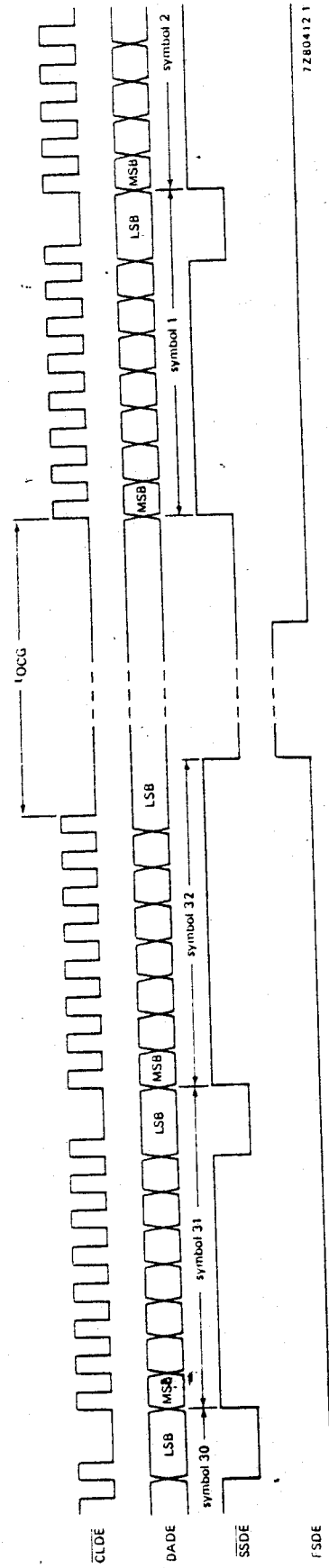

Fig. 5 Typical waveform outputs to SAA7020.

FUNCTIONAL DESCRIPTION (continued)

A delayed version of the sync coincidence pulse resets the divide-by-588 master counter. This counter is reset only by coincident sync pulses or sync pulses which occur during a predetermined 'window' at the start of each frame and is therefore protected from accidental reset by erroneous sync patterns. The window is wide enough to allow PLL bit-slips but narrow enough to avoid false sync signals generated by corrupt data. The divide-by-588 master counter may be allowed to free-run by taking $\overline{\text{CRI}}$ input (pin 11) LOW to inhibit the reset signal.

The divide-by-588 master counter and the second divide-by-17 symbol rate counter are used to time the data and clock outputs to the error corrector SAA7020 (Fig. 5). In this way, even if the data has been corrupted, the timing signals will be correct and are only re-synchronized after a complete frame has been sent to SAA7020.

The data output to SAA7020 comprises thirty-two 8-bit symbols per frame, with half-bit gaps between each symbol and a much longer gap during the frame sync period. It is this longer gap that changes in length when corrupt data upsets the timing system.

Pin functions

pin no.	mnemonic	description
1	V _{BB}	Back bias supply voltage: $-2,5 \text{ V} \pm 20\%$.
2	SDATA	Subcoding data push-pull output. An 8-bit burst of data (including a 1-bit subcoding frame sync) is output serially once per frame coincident with SBCL.
3	SBCL	Subcoding bit clock push-pull output. An 8-bit burst clock, typically at 2,1609 MHz, is used to synchronize the subcoding data.
4	SWCL	Subcoding word clock push-pull output. A square-wave signal at data frame rate (7,35 kHz) used to synchronize the subcoding words and the pause (P) bit.
5	P	Subcoding pause bit push-pull output. This signal is derived from the encoded subcoding word and is used to indicate a music pause. A debounce circuit is incorporated to eliminate erroneous data.
6	HFD/TEST	External high-frequency detector input. When this signal is HIGH the frequency detector output (FD) and phase detector are enabled. When pin 6 is connected to V _{DD2} , the device enters TEST mode.
7	HF11	Level detector input. A signal of between 0,25 and 2,5 V (peak-to-peak value) is required to drive the level detector correctly.
8	FB	Current feedback from the level detector.
9	n.c.	Not connected.
10	HF12	Alternative input to the level detector.
11	$\overline{\text{CRI}}$	Counter reset inhibit signal input. When LOW, this signal allows the divide-by-588 master counter to free-run and causes pin 27 output to be converted to DEFM. During power-up, pin 11 should be held HIGH for 10 ms.
12	PD2	Phase detector reference signal, maximum impedance 10 k Ω .
13	PD1	Phase detector output signal, maximum impedance 10 k Ω . The differential d.c. content of PD1 and PD2 signals is a measure of the phase difference between the data and the internal 4,3218 MHz clock.

DEMODULATOR FOR COMPACT DISC

SAA7010

pin no.	mnemonic	description
14	VSSD	Digital ground. Main ground terminal.
15	VDD2	Positive supply voltage: + 12 V \pm 10%.
16	OA1	Operational amplifier non-inverting input.
17	OA2	Operational amplifier inverting input.
18	OA3	Operational amplifier source follower output.
19	VSSA	Analogue ground. Ground terminal for operational amplifier and VCO only. Connected internally to VSSD via a 25 Ω (nominal) resistor.
20	VCO1	Voltage-controlled oscillator amplifier input. The amplifier is a simple inverter operating up to 10 MHz. Frequency control is achieved via an external tuned circuit using variable capacitance diodes.
21	VCO2	Voltage-controlled oscillator amplifier output. The load for the inverting transistor may be turned off for test purposes by reducing VDD2 to 0 V.
22	CEFM	Internal 4,3218 MHz clock generator push-pull output.
23	FD	Frequency detector three-state push-pull output. This output has a 1 k Ω load. This output is in a high-impedance state when the chip is in standby mode.

RATINGS

Limiting values in accordance with the Absolute Maximum Rating System (IEC 134);

$V_{SSA} = V_{SSD} = 0 \text{ V}$.

Supply voltage 1 range (pin 28)	V_{DD1}	-0,3 to +7,5 V
Supply voltage 2 range (pin 15)	V_{DD2}	-0,3 to +15 V
Back bias supply voltage range (pin 1)	V_{BB}	-4 to +0,3 V
Input voltage range	V_I	-0,3 to +7,5 V
Output voltage range (except FD, OA3)	V_O	-0,3 to +7,5 V
Output voltage range (FD, OA3 only)	V_O	-0,3 to +15 V
Output current (each output)	I_O	max. 10 mA
Operating ambient temperature range	T_{amb}	-20 to +70 °C
Storage temperature range	T_{stg}	-55 to +125 °C

3

CHARACTERISTICS

$V_{SSA} = V_{SSD} = 0 \text{ V}$; $T_{amb} = -20 \text{ to } +70 \text{ °C}$ unless otherwise specified

parameter	symbol	min.	typ.	max.	unit
SUPPLIES					
Supply voltage 1 (pin 28)	V_{DD1}	4,5	5,0	5,5	V
Supply voltage 2 (pin 15)	V_{DD2}	10,8	12,0	13,2	V
Back bias supply voltage (pin 1)	$-V_{BB}$	2,0	2,5	3,0	V
Supply current 1 (pin 28)	I_{DD1}	30	60	150	mA
Supply current 2 (pin 15)	I_{DD2}	4	8	21	mA
Back bias supply current (pin 1)	$-I_{BB}$	-	-	500	μA
DIGITAL CIRCUITS					
Input HFD, $\overline{\text{CRI}}$					
Input voltage LOW	V_{IL}	-0,3	-	+0,8	V
Input voltage HIGH	V_{IH}	2,4	-	6,5	V
Input current (note 1)	I_I	-1	-	+1	μA
Input capacitance	C_I	-	-	7	pF
Outputs DADE/DEFM, $\overline{\text{CLDE}}$, $\overline{\text{FSDE}}$, $\overline{\text{SSDE}}$, SBCL, SDATA, P, SWCL, $\overline{\text{CEFM}}$ (note 2)					
Output voltage LOW at $-I_{OL} = 1,6 \text{ mA}$	V_{OL}	0	-	0,4	V
Output voltage HIGH at $I_{OH} = 0,2 \text{ mA}$	V_{OH}	3,0	-	$V_{DD1} + 0,5$	V
Load capacitance	C_L	-	-	150	pF

DEMODULATOR FOR COMPACT DISC

SAA7010

parameter	symbol	min.	typ.	max.	unit
DIGITAL CIRCUITS (continued)					
Output FD					
Output voltage LOW at $-I_{OL} = 100 \mu\text{A}$	V_{OL}	0	—	0,5	V
Output voltage HIGH at $I_{OH} = 100 \mu\text{A}$	V_{OH}	8,0	—	$V_{DD2} + 0,5$	V
Output leakage current at $V_O = 0$ to 6 V (note 3)	$\pm I_L$	—	—	1	μA
Output impedance	Z_O	—	1	—	$\text{k}\Omega$
Outputs PD1, PD2					
Output impedance	Z_O	—	5	10	$\text{k}\Omega$
LEVEL DETECTOR					
Inputs HFI1, HFI2					
A.C. input voltage range (peak-to-peak value)	$V_I(\text{p-p})$	0,25	—	2,5	V
Input capacitance	C_I	—	—	7	pF
Output FB					
Output current at $V_{FB} = 2$ V	I_{FB}	—	150	—	μA
OPERATIONAL AMPLIFIER (note 4)					
Inputs OA1, OA2					
Common-mode voltage range	V_{CIM}	1,5	—	6,0	V
Input offset voltage	$\pm V_{IOF}$	—	20	—	mV
Input current (note 1)	$\pm I_I$	—	—	1	μA
Input offset current (note 5)	$\pm I_{IOF}$	—	—	0,1	μA
Input capacitance	C_I	—	—	7	pF
Common-mode rejection ratio	CMRR	40	—	—	dB
Open loop gain (d.c.)	A	40	—	—	dB
Gain bandwidth product (20 dB/decade roll-off)		1	5	—	MHz
Output OA3					
Output voltage LOW at $-I_{OL} = 1$ mA	V_{OL}	0	—	1	V
Output voltage HIGH at $I_{OH} = 1$ mA	V_{OH}	8,0	—	$V_{DD2} + 0,5$	V

DEMODULATOR FOR COMPACT DISC

SAA7010

CHARACTERISTICS (continued)

parameter	symbol	min.	typ.	max.	unit
VCO					
Input VCO1, output VCO2					
Mutual conductance at 100 kHz	g_m	1,5	—	—	mA/V
Bandwidth (−3 dB cut-off)	B_{gm}	20	—	—	MHz
Input capacitance	C_i	—	—	7	pF
Output capacitance	C_o	—	—	7	pF
Feedback capacitance	C_{FB}	—	—	5	pF
Input leakage current (note 1)	$\pm I_l$	—	—	1	μA
Output current at 10 MHz	$\pm I_o$	—	1	—	mA
Small-signal voltage gain at 100 kHz	A_v	4	—	—	V/V
TIMING					
Operating frequency (except VCO)	F_{CEFM}	0,1	—	5	MHz
Operating frequency (VCO only)	F_{VCO}	0,2	—	10	MHz
Outputs \overline{CLDE}, DADE, \overline{SSDE}, FSDE, \overline{CEFM} (Fig. 6 and note 6)					
Output rise time	t_{OR}	—	—	50	ns
Output fall time	t_{OF}	—	—	40	ns
\overline{CLDE} period	t_{OCP}	400	—	—	ns
\overline{CLDE} HIGH time	t_{OCH}	150	—	—	ns
\overline{CLDE} LOW time	t_{OCL}	150	—	—	ns
DADE/ \overline{SSDE} /FSDE to \overline{CLDE} set-up time	t_{ODS}	100	—	—	ns
\overline{CLDE} to DADE/ \overline{SSDE} /FSDE hold time	t_{ODH}	100	—	—	ns
\overline{SSDE} LOW time (note 7)	t_{SSL}	—	3	—	\overline{CEFM}
\overline{CLDE} LOW time during FSDE (Fig. 5 and note 8)	t_{OCG}	16	46	—	period
Outputs SBCL, SDATA, P, SWCL (Fig. 7)					
Output rise time (SBCL, SDATA) (note 6)	t_{OR}	—	—	50	ns
Output fall time (SBCL, SDATA) (note 6)	t_{OF}	—	—	40	ns
Output rise time (P, SWCL) (note 9)	t_{OSR}	—	—	200	ns
Output fall time (P, SWCL) (note 9)	t_{OSF}	—	—	200	ns
SBCL HIGH time	t_{OCH}	150	—	—	ns
SBCL LOW time	t_{OCL}	150	—	—	ns
SDATA to SBCL set-up time	t_{ODS}	100	—	—	ns
P to SWCL set-up time	t_{ODSP}	1	—	—	ns
SBCL to SDATA hold time	t_{ODH}	100	—	500	ns
SBCL to SWCL hold time	t_{SWH}	0	—	—	μs
SWCL duty cycle (t_{HIGH}/t_{period})		40	50	60	%

3

DEMODULATOR FOR COMPACT DISC

SAA7010

parameter	symbol	min.	typ.	max.	unit
TIMING (continued)					
Output FD					
Output rise time (note 6)	t _{FDR}	—	—	1	μs
Output fall time (note 6)	t _{FDF}	—	—	1	μs
Outputs DEFM, $\overline{\text{CEFM}}$ (Fig. 8)					
Output rise time (note 6)	t _{OR}	—	—	50	ns
Output fall time (note 6)	t _{OF}	—	—	40	ns
DEFM to $\overline{\text{CEFM}}$ set-up time (note 10)	t _{ODS}	50	—	—	ns
$\overline{\text{CEFM}}$ to DEFM hold time (note 10)	t _{ODH}	70	—	—	ns
$\overline{\text{CEFM}}$ HIGH time	t _{OCH}	50	—	—	ns
$\overline{\text{CEFM}}$ LOW time	t _{OCL}	50	—	—	ns

NOTES TO THE CHARACTERISTICS

1. At $T_{\text{amb}} = 25^\circ\text{C}$; $V_{\text{IN}} = -0,3$ to $+6,5$ V; $V_{\text{DD1}} = 6,5$ V.
2. Short-circuit protected to V_{DD1} and V_{SS} . The maximum load capacitance that can be applied before short-circuit protection becomes operative is 150 pF.
3. At $T_{\text{amb}} = 25^\circ\text{C}$; output in high impedance state.
4. All tests performed within common-mode voltage range.
5. At $T_{\text{amb}} = 25^\circ\text{C}$.
6. Output loading = 50 pF.
7. $\overline{\text{SSDE}}$ remains LOW for only one negative edge of $\overline{\text{CLDE}}$.
8. Excessive bit-slip may cause gap to disappear. $\overline{\text{CLDE}}$ remains LOW when FSDE is HIGH.
9. Output loading = 150 pF.
10. Free running VCO frequency tuned to nominal and PLL in lock with a typical application circuit.

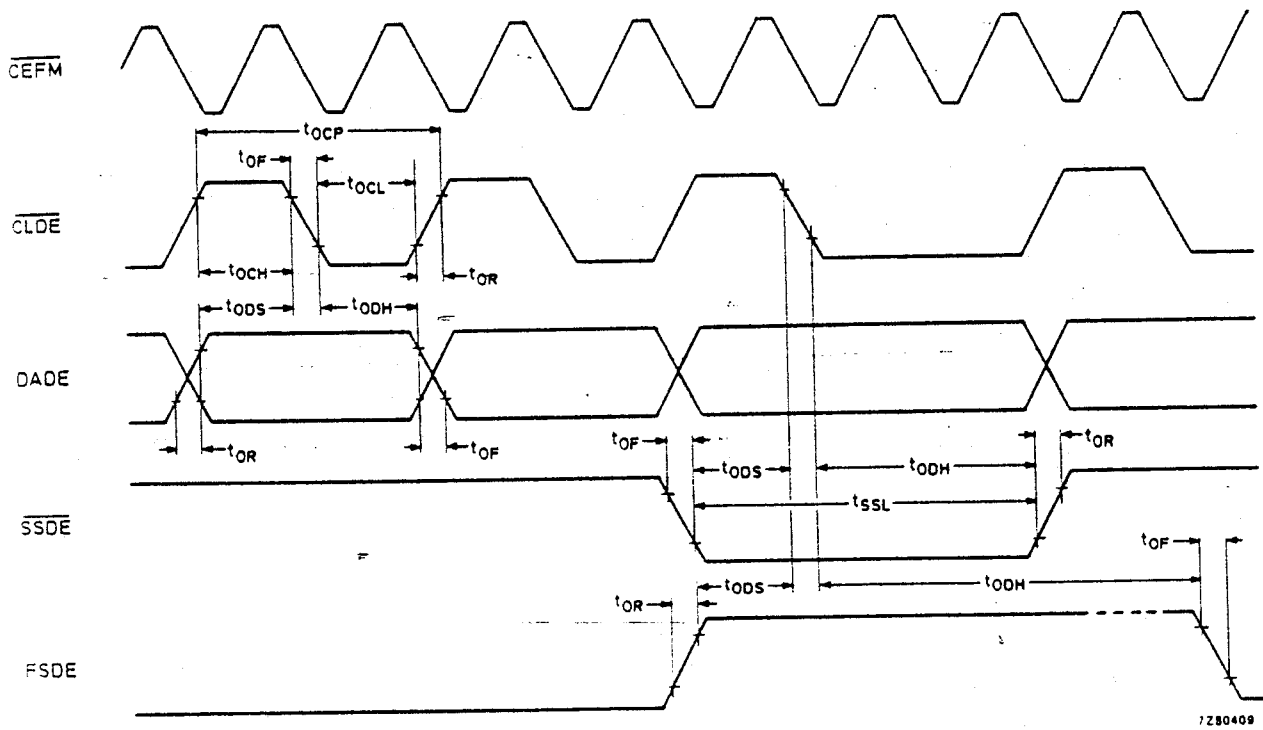

3

Fig. 6 Timing of waveform outputs to SAA7020.

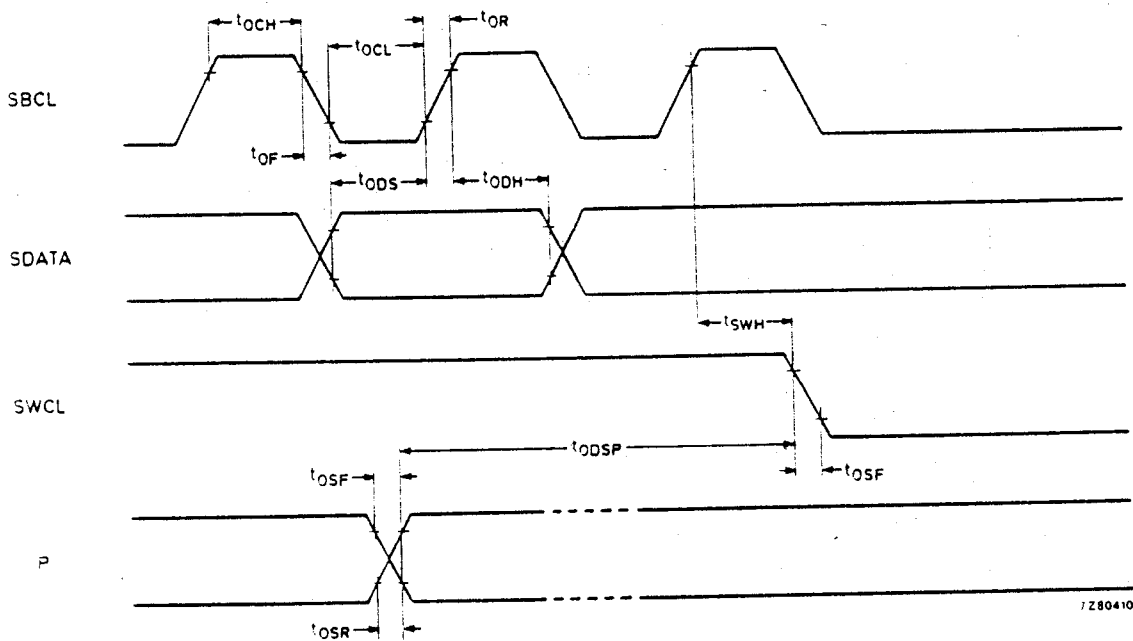

Fig. 7 Timing of waveform outputs for subcoding: reference levels are 0,8 and 2,4 V; SBCL and SDATA output loading = 50 pF; SWCL and P output loading = 150 pF; SWCL has a 50% duty cycle.

DEMODULATOR FOR COMPACT DISC

SAA7010

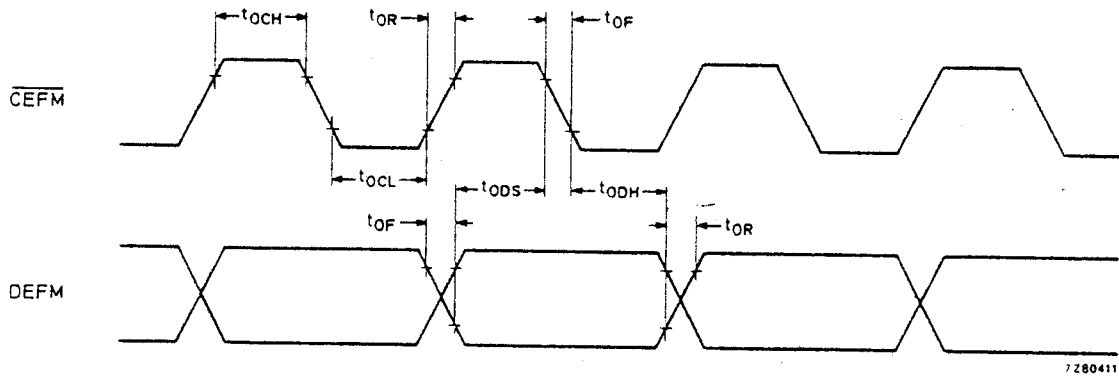

Fig. 8 Timing of EFM output waveforms: output loading = 50 pF; reference levels are 0,8 and 2,4 V.